

# GENERAL INFORMATION

---



## DATES

---

October 22, 2017      Stand Installation of Exhibition Area  
October 23-25, 2017      Exhibition Dates

## CONGRESS CENTER

---

### Hilton Prague

**Address:** Pobřežní 1, 186 00, Praha 8, Czech Republic

**Phone:** +420 224 841 111

## TIME TABLE

---

**Setting up of exhibits**      October 22  
**Taking down of exhibits**      October 26

## EXHIBITION PACKAGE INCLUDES

---

- Exhibition stand area for 3 event days
  - One counter with shelf and foamboard branding, two barstools, power sockets
- The counter sizing is based on sponsorship level and will be provided as follows:

### Diamond & Platinum

2 m counter

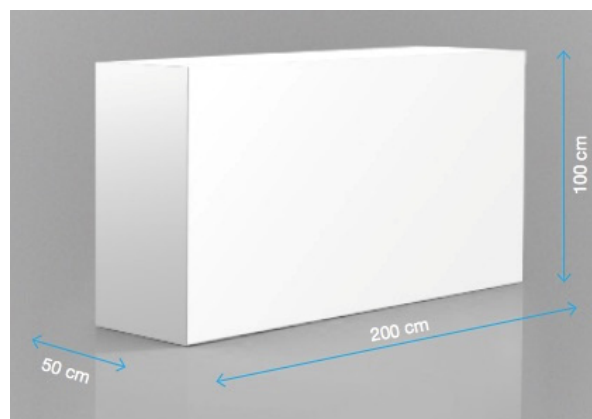

# GENERAL INFORMATION

---

## Gold

1.4 m counter

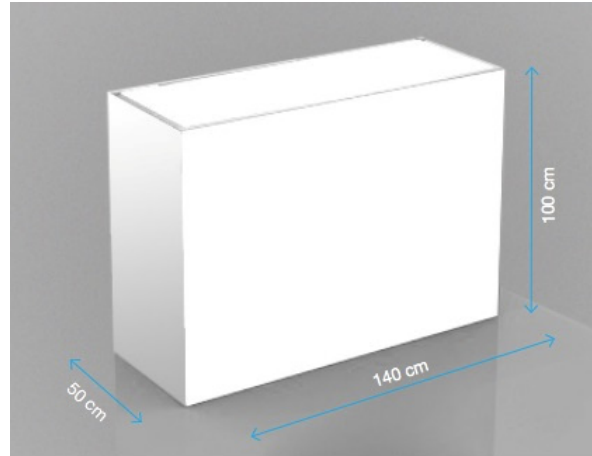

## Silver & Bronze

1 m counter

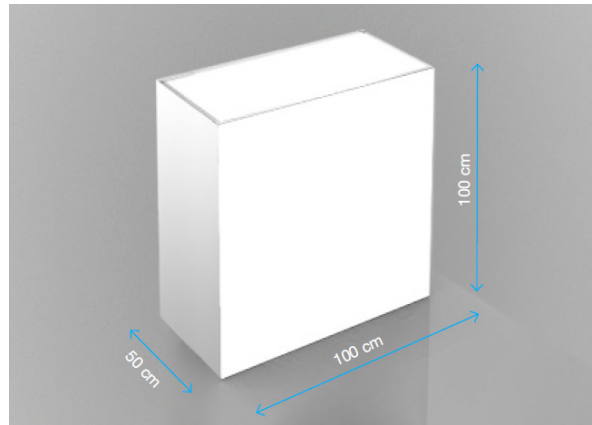

# BOOTH UPGRADES - Deadline: 2nd October 2017



EXHIBITOR NAME: \_\_\_\_\_

STAND NUMBER \_\_\_\_\_

SIGNATURE: \_\_\_\_\_

DATE: \_\_\_\_\_

|  |   |                |
|--|---|----------------|
|  | <b>BOOTH UPGRADE OPTION 1</b>   | <b>385 EUR</b> |
|  | • Backwall (w x h): 150 x 200 cm  |                |
|  | <b>BOOTH UPGRADE OPTION 2</b>   | <b>415 EUR</b> |
|  | • Backwall (w x h): 200 x 200 cm  |                |
|  | <b>BOOTH UPGRADE OPTION 3</b>   | <b>795 EUR</b> |
|  | • Kiosk (w x h): 100 x 200 cm, including mounted 40" LCD screen   |                |
|  | <b>CUSTOM BUILT STAND</b>   |                |
|  | We can build custom stands for you of any dimensions depending on the venue. You may ask us to design one for you against your requirements or you may send in your own design and we can construct and set it up for you. Please email us at <a href="mailto:marietta.bertok@speceffect.com">marietta.bertok@speceffect.com</a> (Attn.: Ms. Marietta Bertok) for our quote for design and construction or simply construction. |                |
|  | <b>Other requested materials</b> will be calculated separately on request.  |                |

**The above prices do not include: stand cleaning, internet connection, telephone lines, power consumption, additional furniture, additional audiovisual equipment and any additional services.**

**Please mark the requested areas.**

# BOOTH UPGRADES - Deadline: 2nd October 2017

---

## BOOTH UPGRADE BACKWALL EXAMPLES\*

---

\* The pictures displayed for illustration purposes only.

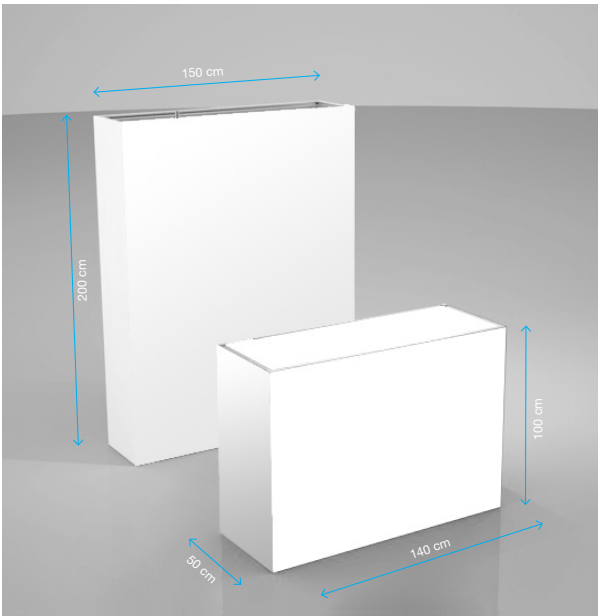

Option 1

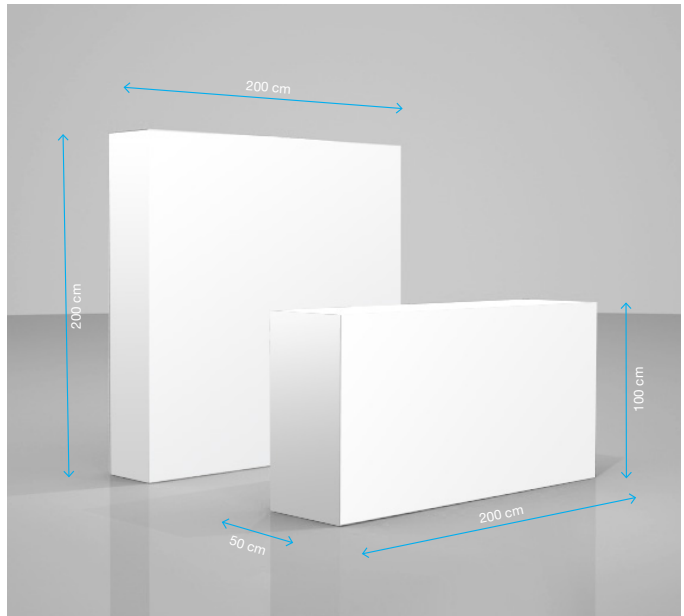

Option 2

## BOOTH UPGRADE KIOSK EXAMPLE\*

---

\* The picture displayed for illustration purposes only.

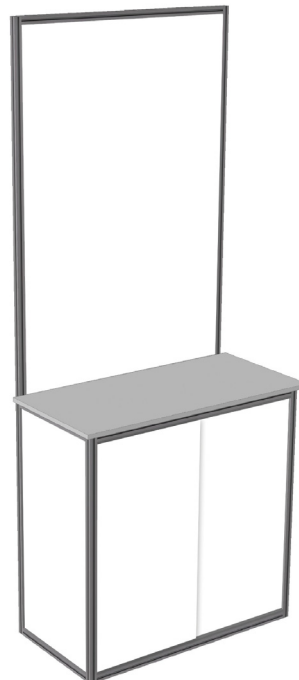

Option 3

# FURNITURE & EQUIPMENT CATALOG

---



Furniture / Equipment quotes are per item and valid for the period of the exhibition except audiovisual equipment (price per day).

All prices include the installation of the furniture / equipment at your stand.

The exact technical details and description of each equipment can be provided upon request.

If you do not find the furniture / equipment on the list that suits your need, please contact Special Effects for more details and other type of furniture / equipment.

**In order to place your order, please fill in the attached order form and the separately attached VAT form and e-mail it to us.**

## CONTACT INFORMATION

---

Please send your request to the following email address.

**Ms. Marietta Bertok**

[marietta.bertok@speceffect.com](mailto:marietta.bertok@speceffect.com)

**101 | GREY TABLE**

**Price: 18 EUR**

Size (w x d x h): 80 x 80 x 74 cm



**102 | GREY TABLE**

**Price: 22 EUR**

Size (w x d x h): 120 x 80 x 74 cm



**103 | ROUND GREY TABLE**

**Price: 27 EUR**

Size (ø x h): 70 x 74 cm



**104 | ROUND GLASS TABLE**

**Price: 35 EUR**

Size (ø x h): 80 x 74 cm



**105 | ROUND GLASS COFFEE TABLE**

**Price: 52 EUR**

Size (ø x h): 80 x 74 cm



**106 | ROUND FRENCH TABLE**

**Price: 45 EUR**

Size (ø x h): 80 x 75 cm



**107 | LED TABLES**

**Price: 120 EUR**

Size (ø x h): 84 x 45/75/105 cm



**108 | FRENCH TABLE**

**Price: 45 EUR**

Size (w x d x h): 80 x 80 x 75 cm



**109 | WHITE TABLE****Price: 60 EUR**

Size (w x d x h): 120 x 80 x 75 cm

**110 | CONSOLE TABLE 1****Price: 90 EUR**

Size (w x d x h): 100 x 60 x 110 cm

**111 | CONSOLE TABLE 2****Price: 110 EUR**

Size (w x d x h): 200 x 60 x 110 cm

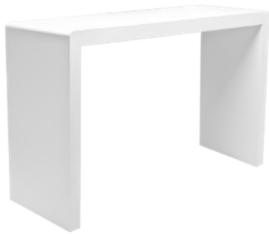
**112 | CONSOLE TABLE 3****Price: 145 EUR**

Size (w x d x h): 300 x 60 x 110 cm

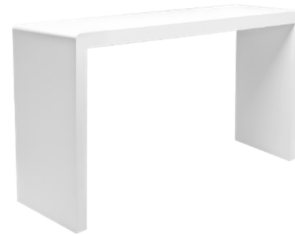
**113 | BAR TABLE****Price: 60 EUR**

Size (ø x h): 60 x 106 cm

**114 | BLACK COFFEE TABLE****Price: 32 EUR**

Size (w x d x h): 55 x 55 x 45 cm

**115 | LOCKABLE CABINET****Price: 52 EUR**

Size (w x d x h): 90 x 45 x 75 cm



**201 | GREY UPHOLSTERED CHAIR**

**Price: 13 EUR**

Size (w x d x h): 47 x 41 x 45/82 cm



**202 | GREY UPHOLSTERED CHAIR**

**Price: 20 EUR**

Size (w x d x h): 45 x 45 x 45/81 cm



**203 | WHITE SHELL CHAIR**

**Price: 30 EUR**

Size (w x d x h): 43 x 38 x 47/90 cm



**204 | BLUE UPHOLSTERED CHAIR**

**Price: 20 EUR**

Size (w x d x h): 47 x 41 x 45/82 cm



**205 | RED UPHOLSTERED CHAIR**

**Price: 20 EUR**

Size (w x d x h): 47 x 41 x 45/82 cm



**206 | CREAM LEATHERETTE CHAIR**

**Price: 20 EUR**

Size (w x d x h): 47 x 41 x 45/82 cm



**207 | WHITE LEATHERETTE CHAIR**

**Price: 40 EUR**

Size (w x d x h):



**208 | BLACK UPHOLSTERED CHAIR**

**Price: 22 EUR**

Size (w x d x h):





**209 | BLACK SHELL CHAIR****Price: 12 EUR**

Size (w x d x h):

**210 | OFFICE ARMCHAIR****Price: 45 EUR**

Size (w x d x h): 48 x 47 x 42-52/108 cm

**211 | POUFFE / FOOTSTOOL****Price: 18 EUR**

Size (w x d x h): 55 x 45 x 46 cm (black/white)

**212 | BARSTOOL BOMBO****Price: 32 EUR**

Size (w x d x h): 40 x 38 x 66-86 cm (white/red)

**213 | Z BARSTOOL****Price: 22 EUR**

Size (ø x h): 36 x 83 cm

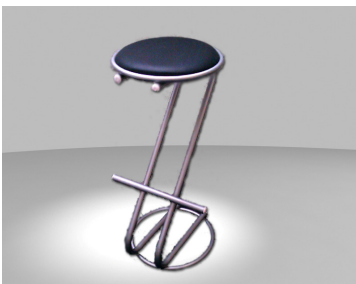
**214 | BISTRO BARSTOOL****Price: 40 EUR**

Size (w x d x h): 40 x 40 x 66-87 cm

**215 | BARSTOOL LIGHT****Price: 32 EUR**

Size (w x d x h): 50 x 52 x 77/100 cm

**216 | LEM BARSTOOL****Price: 45 EUR**

Size (w x d x h): 40 x 40 x 66-87 cm



**217 | EROS CHAIR**

**Price: 65 EUR**

Size (w x d x h): 62 x 70 x 46/79 cm



**218 | CLUB CHAIR STYLE**

**Price: 39 EUR**

Size (w x d x h): 47 x 43 x 48/80 cm



**219 | WHITE ARMCHAIR**

**Price: 62 EUR**

Size (w x d x h): 69 x 59 x 76 cm



**220 | ROUND WHITE SOFA**

**Price: 105 EUR**

Size (w x d x h): 118 x 59 x 76 cm



**221 | SOFA STYLE**

**Price: 120 EUR**

Size (w x d x h): 180 x 88 x 66/93 cm (white/black)



**222 | BLACK ARMCHAIR**

**Price: 62 EUR**

Size (w x d x h): 69 x 59 x 76 cm



**223 | BLACK SOFA**

**Price: 120 EUR**

Size (w x d x h): 118 x 59 x 76 cm



**301 | TABLE TOP LITERATURE**

**Price: 26 EUR**

Size (w x d x h):



**302 | WOODEN EASEL**

**Price: 32 EUR**

Size (w x d x h): 66 x 66 x 160 cm



**303 | PLASTIC PAPER BIN**

**Price: 5 EUR**

Size (w x d x h):

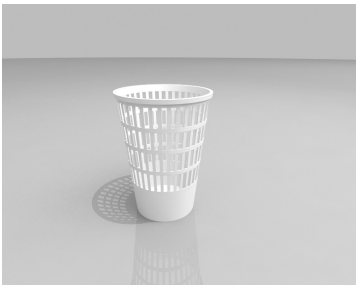

**304 | BARRIER**

**Price: 22 EUR**

Size (w x d x h):



**305 | INFORMATION BOARD**

**Price: 70 EUR**

Size (w x d x h):



**306 | FREE STANDING LITERATURE HOLDER**

**Price: 55 EUR**

Size (w x d x h):

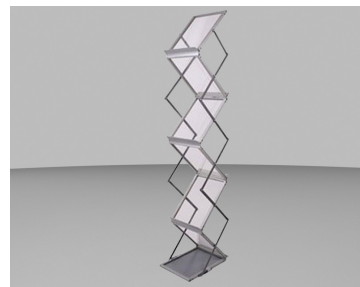

**307 | STANDING COAT RACK**

**Price: 30 EUR**

Size (w x d x h):

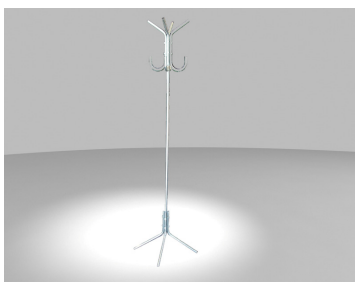

**308 | WOODEN SHELF**

**Price: 32 EUR**

Size (w x d x h): 95 x 35 x 200 cm



**401 | ROLL-UP**

**Price: 130 EUR**

Size (w x d x h): 85 x 200 cm



**402 | A3 SIZE ROLL-UP**

**Price: 110 EUR**

Size (w x d x h): 29,7 x 42 cm



**501 | 19" LCD MONITOR**

**Price per day: 75 EUR**



**502 | 40" LCD SCREEN**

**Price per day: 200 EUR**

Full HD



**503 | 46" LCD SCREEN**

**Price per day: 215 EUR**

Full HD



**504 | 55" LCD SCREEN**

**Price per day: 255 EUR**

Full HD



**505 | LAPTOP (MAC)**

**Price per day: 150 EUR**



**506 | LAPTOP (PC)**

**Price per day: 105 EUR**



**507 | DVD PLAYER**

**Price per day: 60 EUR**



**508 | EXTENSION CORD**

**Price per 3 days: 10 EUR**



# ORDER FORM - Deadline: 2nd October 2017



**EXHIBITOR NAME:** \_\_\_\_\_

**STAND NUMBER** \_\_\_\_\_

**SIGNATURE:** \_\_\_\_\_

**DATE:** \_\_\_\_\_

**Full pre-payment is required via bank transfer to the following bank account (please see next page for details).**

| DESCRIPTION                    | COMMENT | PRICE/UNIT<br>(EUR) | QUANTITY | AMOUNT |
|--------------------------------|---------|---------------------|----------|--------|
| <b>FURNITURE</b>               |         |                     |          |        |
| 101   Grey table               |         | 18                  |          |        |
| 102   Grey table               |         | 22                  |          |        |
| 103   Round grey table         |         | 27                  |          |        |
| 104   Round glass table        |         | 35                  |          |        |
| 105   Round glass coffee table |         | 52                  |          |        |
| 106   Round french table       |         | 45                  |          |        |
| 107   LED tables               |         | 120                 |          |        |
| 108   French table             |         | 45                  |          |        |
| 109   White table              |         | 60                  |          |        |
| 110   Console table 1          |         | 90                  |          |        |
| 111   Console table 2          |         | 110                 |          |        |
| 112   Console table 3          |         | 145                 |          |        |
| 113   Bar table                |         | 60                  |          |        |
| 114   Black coffee table       |         | 32                  |          |        |
| 115   Lockable cabinet         |         | 52                  |          |        |
| 201   Grey upholstered chair   |         | 13                  |          |        |
| 202   Grey upholstered chair   |         | 20                  |          |        |
| 203   White shell chair        |         | 30                  |          |        |
| 204   Blue upholstered chair   |         | 20                  |          |        |
| 205   Red upholstered chair    |         | 20                  |          |        |
| 206   Cream leatherette chair  |         | 20                  |          |        |
| 207   White leatherette chair  |         | 40                  |          |        |
| 208   Black upholstered chair  |         | 22                  |          |        |
| 209   Black shell chair        |         | 12                  |          |        |
| 210   Office armchair          |         | 45                  |          |        |
| 211   Pouffe / Footstool       |         | 18                  |          |        |
| 212   Barstool bombo           |         | 32                  |          |        |
| 213   Z barstool               |         | 22                  |          |        |
| 214   Bistro barstool          |         | 40                  |          |        |
| 215   Barstool light           |         | 32                  |          |        |
| 216   Lem barstool             |         | 45                  |          |        |
| 217   Eros chair               |         | 65                  |          |        |
| 218   Club chair style         |         | 39                  |          |        |

# ORDER FORM - Deadline: 2nd October 2017

| DESCRIPTION                           | COMMENT | PRICE/UNIT<br>(EUR) | QUANTITY | AMOUNT |
|---------------------------------------|---------|---------------------|----------|--------|
| <b>FURNITURE</b>                      |         |                     |          |        |
| 219   White armchair                  |         | 62                  |          |        |
| 220   Round white sofa                |         | 105                 |          |        |
| 221   Sofa style                      |         | 120                 |          |        |
| 222   Black armchair                  |         | 62                  |          |        |
| 223   Black sofa                      |         | 120                 |          |        |
| 301   Table top literature            |         | 26                  |          |        |
| 302   Wooden easel                    |         | 32                  |          |        |
| 303   Plastic paper bin               |         | 5                   |          |        |
| 304   Barrier                         |         | 22                  |          |        |
| 305   Information board               |         | 70                  |          |        |
| 306   Free standing literature holder |         | 55                  |          |        |
| 307   Standing coat rack              |         | 30                  |          |        |
| 308   Wooden shelf                    |         | 32                  |          |        |
| 401   Roll-up                         |         | 130                 |          |        |
| 402   A3 size roll-up                 |         | 110                 |          |        |
| <b>AUDIOVISUAL EQUIPMENT</b>          |         |                     |          |        |
| 501   19" LCD monitor                 |         | 75 / day            |          |        |
| 502   40" LCD screen                  |         | 200 / day           |          |        |
| 503   46" LCD screen                  |         | 215 / day           |          |        |
| 504   55" LCD screen                  |         | 255 / day           |          |        |
| 505   Laptop (MAC)                    |         | 150 / day           |          |        |
| 506   Laptop (PC)                     |         | 105 / day           |          |        |
| 507   DVD player                      |         | 60 / day            |          |        |
| 508   Extension cord                  |         | 10 / 3 days         |          |        |
| <b>Net Total</b>                      |         |                     |          |        |
| <b>0% VAT *</b>                       |         |                     |          |        |
| <b>TOTAL AMOUNT (EUR)</b>             |         |                     |          |        |

\* Only if Special Effects Ltd. invoices you directly and outside of Hungary and the VAT form provided by Special Effects is filled in and duly signed

# CONTACT PAYMENT SHEET - Deadline: 2nd October 2017



EXHIBITOR CONTRACTING NAME: \_\_\_\_\_

EXHIBITOR CONTRACTING ADDRESS: \_\_\_\_\_

VAT NUMBER \_\_\_\_\_

STAND NUMBER \_\_\_\_\_

CONTACT PERSON: \_\_\_\_\_

TELEPHONE: \_\_\_\_\_

FAX: \_\_\_\_\_

E-MAIL ADDRESS: \_\_\_\_\_

SIGNATURE/STAMP: \_\_\_\_\_

DATE: \_\_\_\_\_

| ORDER SUMMARY          |                           |
|------------------------|---------------------------|
| FORM TITLE             | AMOUNT                    |
| BOOTH UPGRADES         |                           |
| Booth Upgrade Option 1 |                           |
| Booth Upgrade Option 2 |                           |
| Booth Upgrade Option 3 |                           |
| FURNITURE & EQUIPMENT  |                           |
| Furniture              |                           |
| Audiovisual Equipment  |                           |
|                        | <b>Net Total</b>          |
|                        | <b>0% VAT *</b>           |
|                        | <b>TOTAL AMOUNT (EUR)</b> |

\* Only if Special Effects Ltd. invoices you directly and outside of Hungary and the VAT form provided by Special Effects is filled in and duly signed

## FULL PRE-PAYMENT IS REQUIRED VIA BANK TRANSFER TO THE FOLLOWING BANK ACCOUNT:

Name of the Bank: OBERBANK AG  
Address of the Bank: Budapest 1062, Váci út 1-3.  
SWIFT Code: OBKLUHUB  
Bank Account Number: 18400010 - 03534339 - 10101012  
IBAN Number: HU30184000100353433910101012  
Name of the Company: Special Effects International Ltd.  
Address of the Company: Budapest 1155, Wysocki u. 1., Hungary



# ARTWORK INFORMATION - Deadline 2nd October 2017

---



## GENERAL REQUIREMENTS

---

- Required scale is 1:1 (100% of actual size)
- Save artwork in any of the following formats: PDF, EPS or TIFF.
- Provide colors in CMYK color mode. Special Effects International Ltd. cannot take responsibility for any unexpected color deviations resulting from artworks provided in non-CMYK color mode.
- For spot color specifications please provide exact Pantone/PMS codes.
- Non-vector based artworks should be supplied at a minimum of 200 dpi resolution.
- Convert all fonts used in the artwork into curves/outlines before exporting the vector file for printing. Should this be not possible, please provide the exact font type used.
- **Do not include crop marks.**
- Size of emailed artworks must stay below 16 MB, above this size please send artworks via large file transfer sites (e.g. WeTransfer).

To make sure your artwork is printed correctly and in time, please ensure you follow the requirements above. Artworks submitted with different specifications may be subject to extra amendment charges. Special Effects International Ltd. cannot take responsibility for print errors or late deliveries resulting from insufficient or delayed artworks.

If you need any further information or help to qualify your artwork specifications, please feel free to contact us.

## CONTACT INFORMATION

---

Maria IVAN  
Senior Graphic Designer | Architect  
+36 30 730 0500  
[maria.ivan@speceffect.com](mailto:maria.ivan@speceffect.com)



---

## COUNTER GRAPHIC INFORMATION

---

### Diamond & Platinum

2 m counter

Artwork size: 200 x 100 cm

No bleeds required. (\*Bleed is a printing term which refers to the extra graphic content that extends beyond the edges of the final document.)

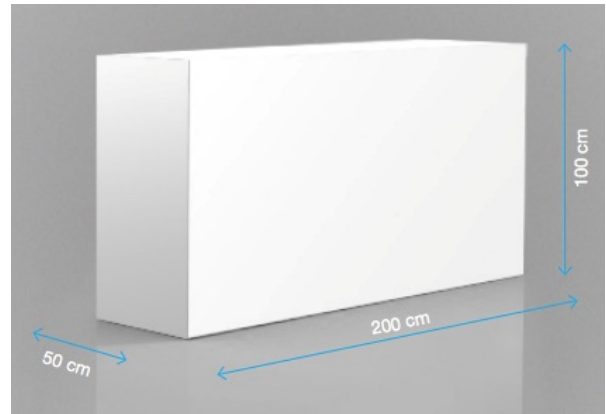

### Gold

1.4 m counter

Artwork size: 140 x 100 cm

No bleeds required.

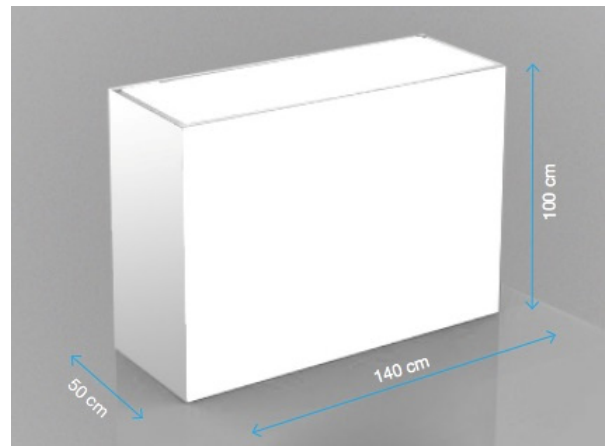

### Silver & Bronze

1 m counter

Artwork size: 100 x 100 cm

No bleeds required.

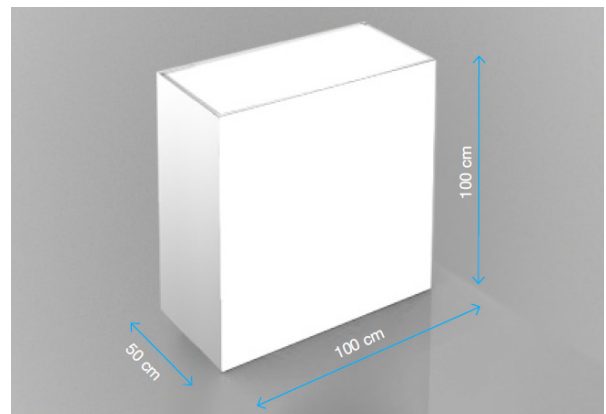



---

## BACKWALL GRAPHIC INFORMATION

---

### Upgrade Option 1

Size (w x h): 150 x 200 cm

Artwork size: 150 x 200 cm

No bleeds required.

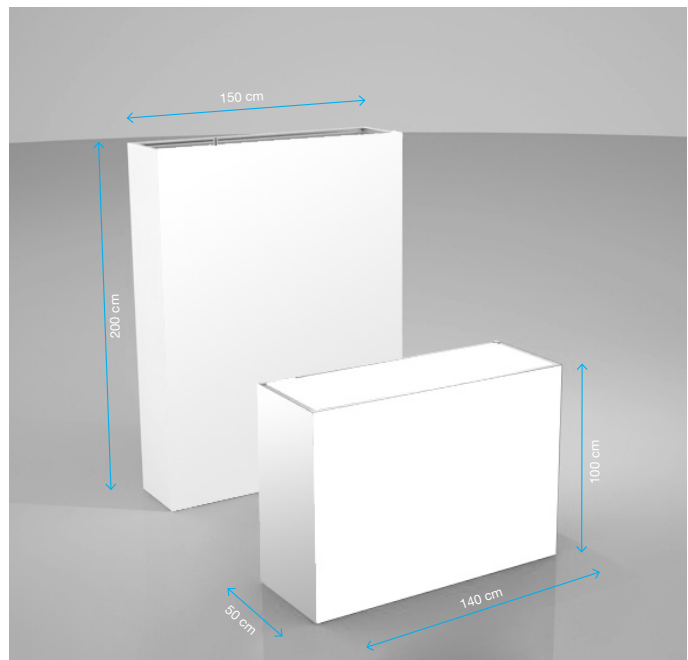

### Upgrade Option 2

Size (w x h): 200 x 200 cm

Artwork size: 200 x 200 cm

No bleeds required.

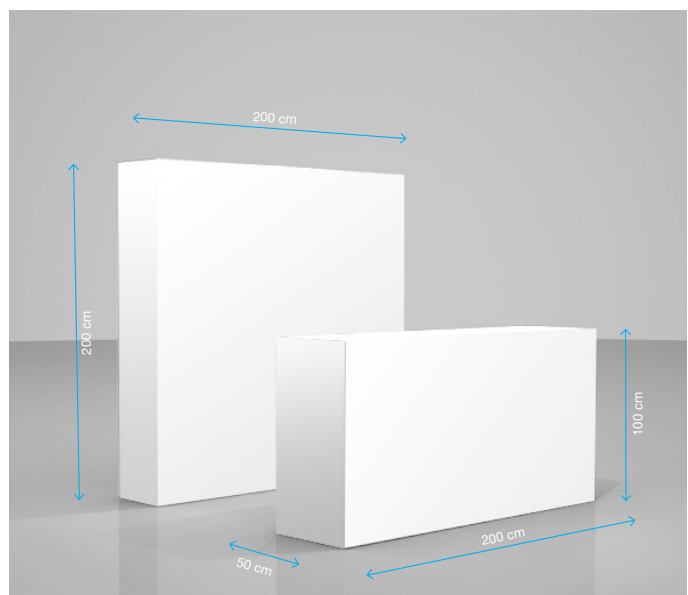



---

## KIOSK GRAPHIC INFORMATION

---

### Upgrade Option 3

Size (w x h): 100 x 200 cm

For artwork sizes please see the below diagram.

Leave 1 cm bleed on all sides of your artwork.

